

REVISIONS

ZONE	REV.	DESCRIPTION	DATE	APPROVED
	IR	INITIAL RELEASE	6/2/2010	R.P.GROVE

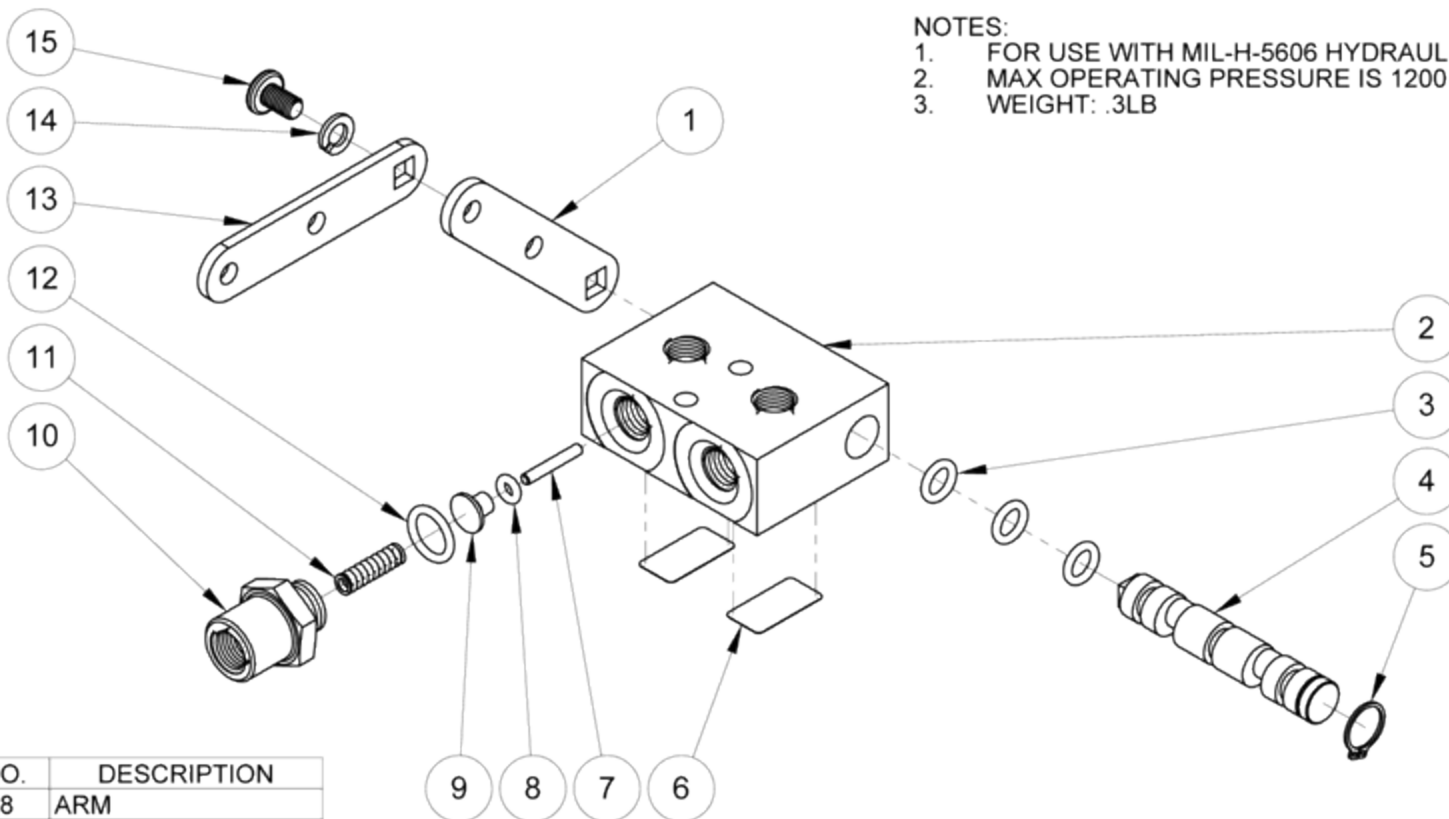

NOTES:

1. FOR USE WITH MIL-H-5606 HYDRAULIC FLUID.
2. MAX OPERATING PRESSURE IS 1200 PSI.
3. WEIGHT: .3LB

ITEM NO.	QTY.	PART NO.	DESCRIPTION
1	1	068-028	ARM
2	1	068-020	BODY
3	3	MS28775-010	O RING (BUNA N)
4	1	068-022	CAM SHAFT
5	1	N5100-37ZD	EXT RETAINING RING
6	2	068-016	LABEL( FLOW )
7	2	068-027	DOWEL PIN
8	2	MS28775-006	O RING (BUNA N)
9	2	068-023	POPPET
10	2	068-026	FITTING
11	2	36022G	SPRING
12	2	MS28775-012	O RING (BUNA N)
13	1	068-024	ARM (ALTERNATE)
14	1	MS35338-43	WASHER
15	1	MS35207-260	SCREW

**Grove**

Aircraft Landing Gear Systems inc.

1800 JOE CROSSON DRIVE, EL CAJON, CA 92020

ASSY, PARK BRAKE VALVE

INTERPRET GEOMETRIC TOLERANCING PER ANSI Y14.5M 1994  
 TOLERANCE  
 DECIMAL 0.XX= +/- .030  
 DECIMAL 0.XXX= +/- .010  
 DECIMAL 0.XXXX= +/- .005  
 ANGLE = 0.25 DEGREES

PART NUMBER:  
068-001

DRAWN BY J. WARWICK	DWG NO. 068-001	REV IR
DATE 6/2/2010	WEIGHT: 3 LB	SCALE 2:3
		SHEET 1 OF 1